

IGW/400-UART

WLAN Device Server

Hardware Reference



SSV Embedded Systems

Heisterbergallee 72
D-30453 Hannover
Phone: +49 (0)511/40 000-0
Fax: +49 (0)511/40 000-40
E-mail: sales@ist1.de

Manual Revision: 1.4
Date: 2006-01-09

CONTENT

1	INTRODUCTION.....	3
1.1	Block Diagram.....	3
1.2	Features IGW/400-UART.....	3
2	OVERVIEW.....	4
3	COMPONENTS.....	5
3.1	14-Pin Environment Interface Connector (EI/O).....	5
3.2	Power LED.....	5
3.3	WLAN Activity LED.....	5
3.4	RS232 Connector (UART1).....	5
3.5	Reverse SMA Connector for WLAN Antenna.....	5
3.6	10/100 Mbps Ethernet Interface.....	5
4	MECHANICAL DIMENSIONS.....	6
4.1	Mechanical Dimensions with DIN-Rail Mounting Set.....	7
4.2	Mechanical Dimensions with Wall Mounting Set.....	8
4.3	Drilling Template for Wall Mounting Set.....	9
5	PIN ASSIGNMENTS.....	10
5.1	14-Pin Environment Interface Connector (EI/O).....	10
5.2	RS232 Connector (UART1).....	10
5.3	10/100 Mbps Ethernet Interface.....	10
	CONTACT.....	11
	DOCUMENT HISTORY.....	11
	COPYRIGHT.....	11

1 INTRODUCTION

The WLAN Device Server IGW/400-UART integrates typical measurement and control interfaces into an IEEE 802.11b/g-compatible WLAN/WiFi Network.

This very compact system acts as small, easy to use interface converter, which collects any data of industrial automation components and transmits it via IEEE 802.11-based WLAN.

This document describes the hardware components of the IGW/400-UART. For further information about the individual components of this product you may follow the links from our website at <http://www.ssv-comm.de>.

Our website contains a lot of technical information, which will be updated in regular periods.

1.1 Block Diagram

Figure 1 shows the block diagram of the IGW/400-UART. UART1 correlates with the RS232 connector (UART1) and the EI/Os correlate with the 14-pin environment interface of the IGW/400-UART.

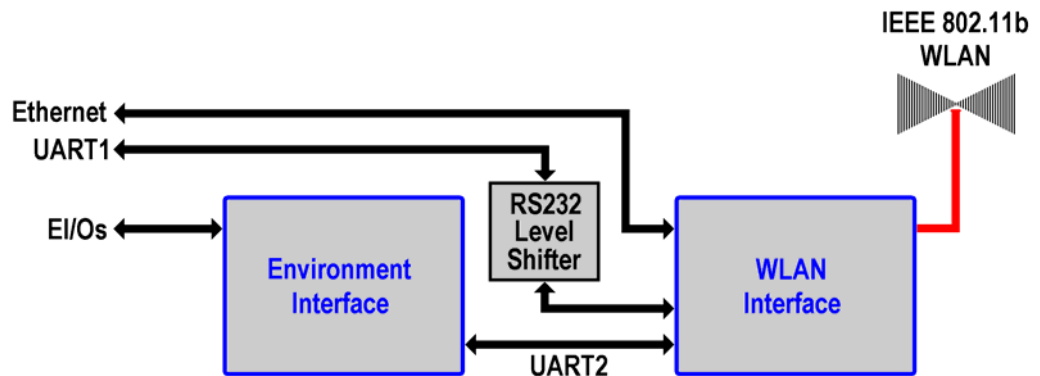
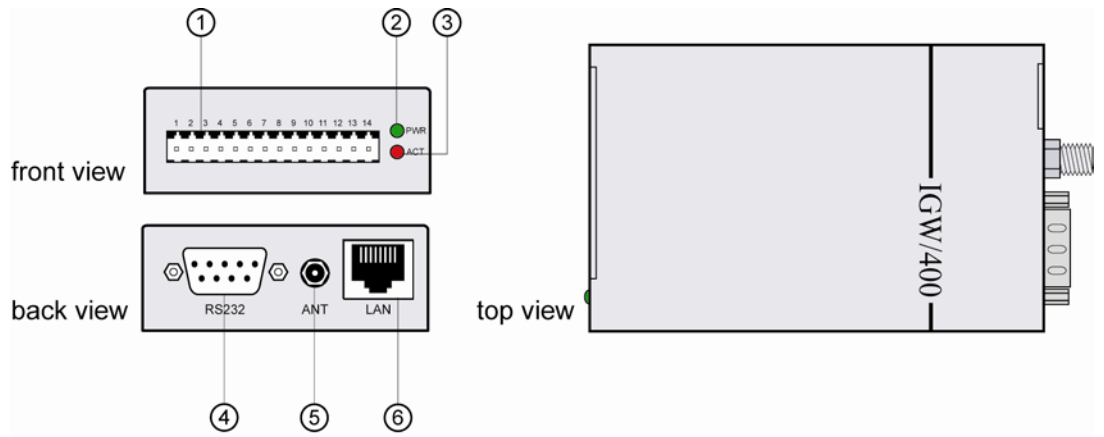

Figure 1: Block diagram of IGW/400-UART

1.2 Features IGW/400-UART

- One 14-pin environment interface connector (EI/O) with RS232/RS422
- One 10/100Mbps Ethernet interface (LAN)
- One RS232 connector (UART1)
- One reverse SMA connector for WLAN antenna
- One power LED (green)
- One WLAN activity LED (red)
- Supply voltage 6 - 30 VDC
- Size 131 x 70 x 26 mm (without antenna)

2 OVERVIEW



- ① 14-pin environment interface connector (EI/O)
- ② Power LED
- ③ WLAN activity LED
- ④ RS232 connector (UART1)
- ⑤ Reverse SMA antenna connector
- ⑥ 10/100 Mbps Ethernet interface

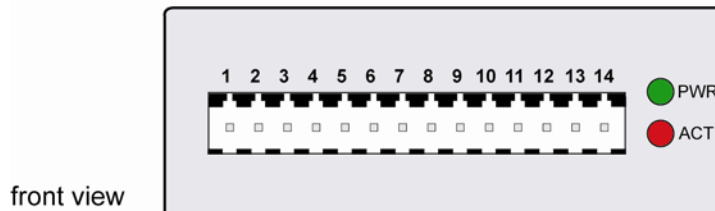

Figure 2: Overview IGW/400-UART

3 COMPONENTS

This chapter describes the components of the IGW/400-UART shown in chapter 2 and gives a short overview about their respective functions.

3.1 14-Pin Environment Interface Connector (EI/O)

The environment interface connector is used to connect the power supply unit via the power supply adapter cable to the pins 1 and 2 of the environment interface. The IGW/400-UART needs a supply voltage of 6 - 30 VDC to work.

Furthermore it is possible to create a RS232 (pins 3 - 8) and a RS422 (pins 10 - 13) connection with the Sub-D adapter cable. Please refer to chapter 5.1 for the complete pinout.

Caution: Providing the IGW/400-UART with a supply voltage higher than 30 VDC could damage the IGW/400-UART!

3.2 Power LED

The green power LED indicates a present supply voltage. This LED is on when the IGW/400-UART is provided with a voltage of 6 - 30 VDC by the power supply. If this LED is off, check the connection between the power supply and the IGW/400-UART. Check also if the power supply is set to 6 - 30 VDC. The default setting of the power supply is 12 VDC.

3.3 WLAN Activity LED

The red WLAN activity LED indicates activity on the WLAN interface. If this LED is off, check the WLAN connection settings of the IGW/400-UART.

3.4 RS232 Connector (UART1)

The IGW/400-UART is equipped with a standard RS232 connector named UART1. This interface comes with a 9 pin Sub-D male connector. The pin assignment of UART1 is identical to the COM port assignment of a PC, so it is possible to use a null-modem cable.

3.5 Reverse SMA Connector for WLAN Antenna

The reverse SMA connector is used to attach the WLAN antenna to the IGW/400-UART.

3.6 10/100 Mbps Ethernet Interface

The IGW/400-UART allows Ethernet connectivity with a speed up to 100 Mbps. The LAN interface of the IGW/400-UART is a standard RJ45 Ethernet interface. The LAN interface is an alternative to the WLAN antenna. You cannot use the LAN interface and the WLAN antenna at the same time.

4 MECHANICAL DIMENSIONS

All length dimensions have a tolerance of 0.5 mm.

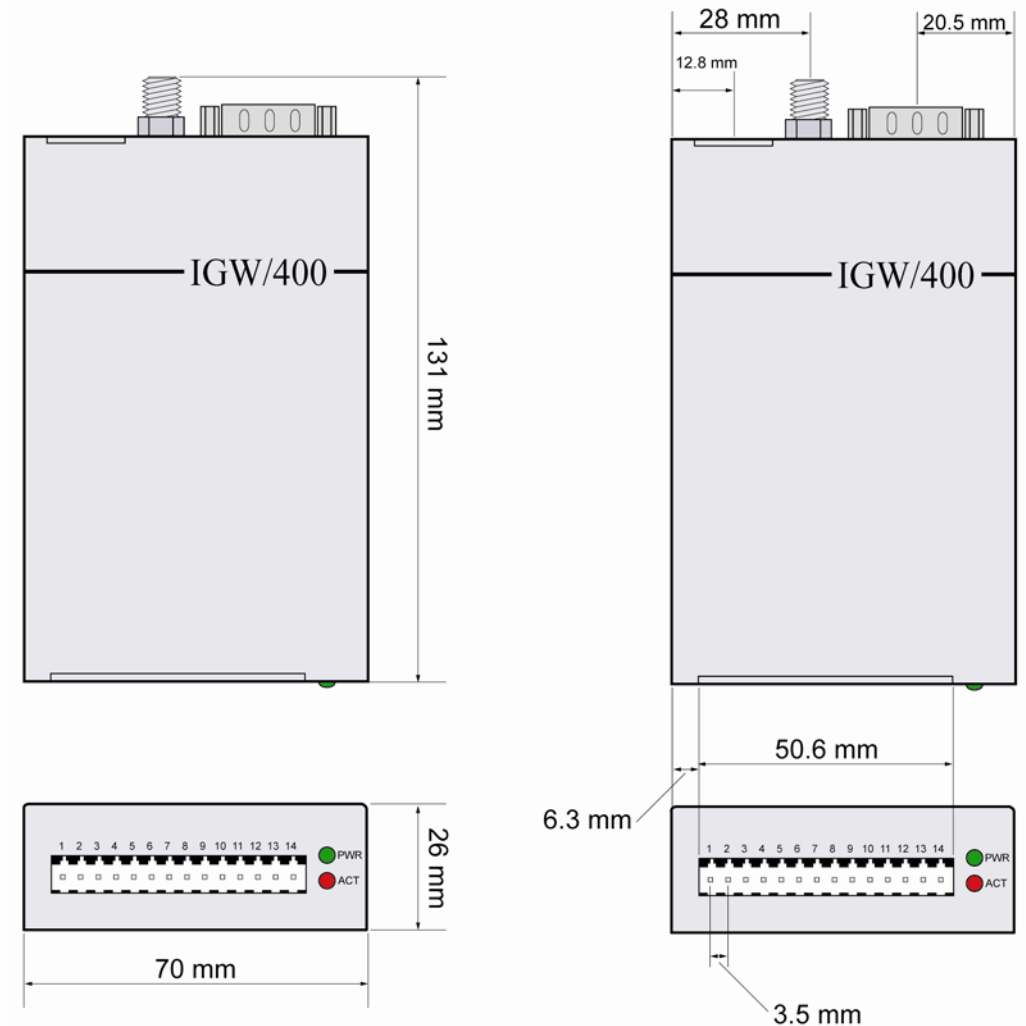

Figure 3: Mechanical dimensions of IGW/400-UART

4.1 Mechanical Dimensions with DIN-Rail Mounting Set

All length dimensions have a tolerance of 0.5 mm.

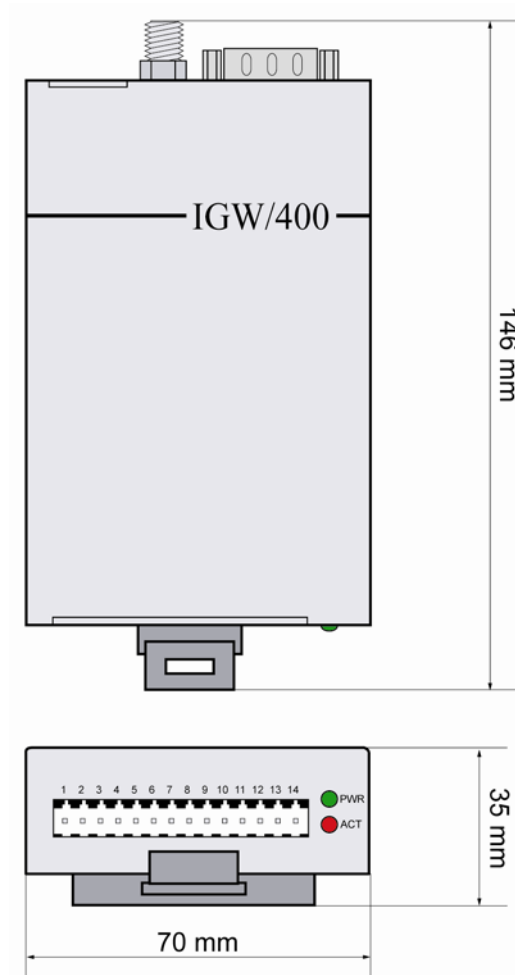

Figure 4: Mechanical dimensions of IGW/400-UART with DIN-rail mounting set

4.2 Mechanical Dimensions with Wall Mounting Set

All length dimensions have a tolerance of 0.5 mm.

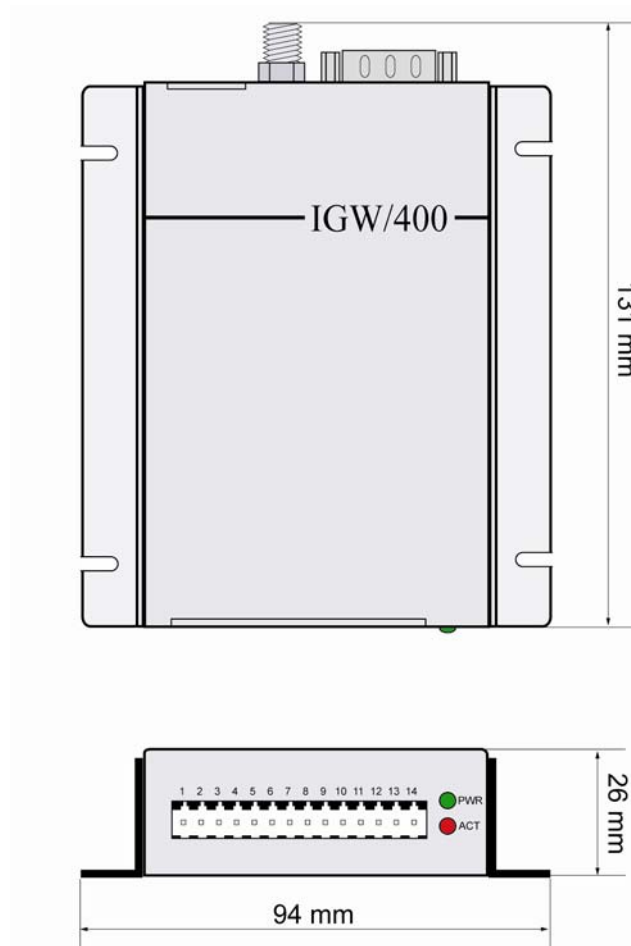

Figure 5: Mechanical dimensions with wall mounting set

4.3 Drilling Template for Wall Mounting Set

All length dimensions have a tolerance of 0.5 mm.

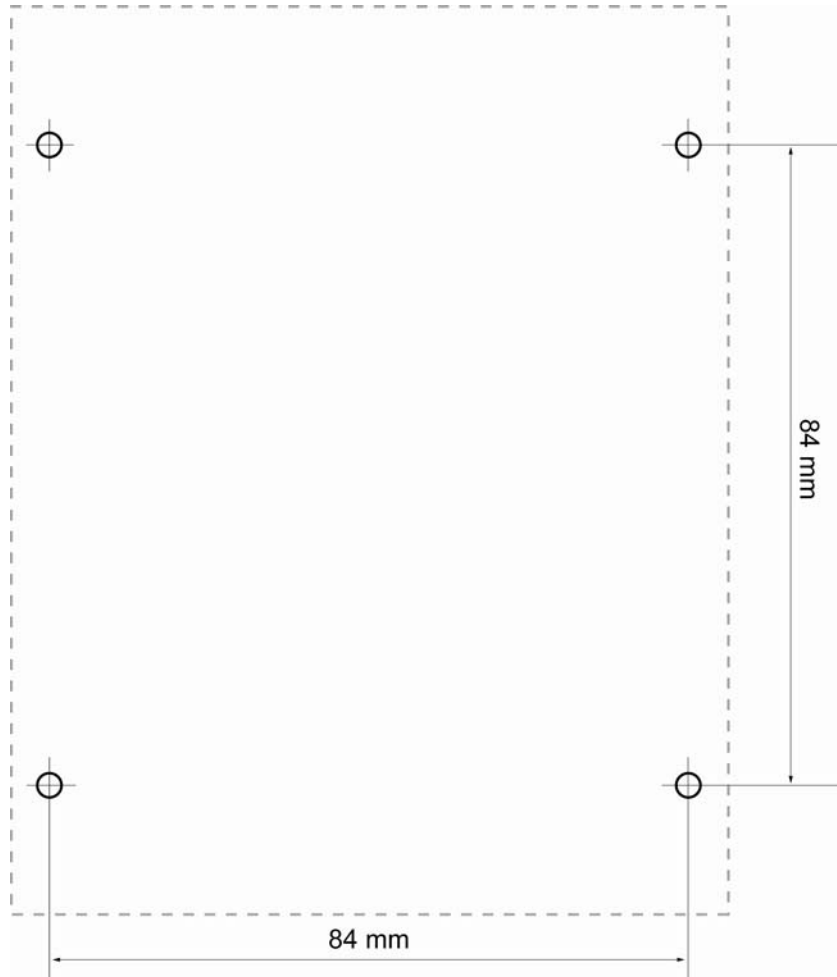

Figure 6: Drilling template for wall mounting set

5 PIN ASSIGNMENTS

5.1 14-Pin Environment Interface Connector (EI/O)

Pin	Name	Function
1	Vin	6 - 30 VDC power input
2	GND	Ground
3	DCD2 (RS232)	UART2 RS232 serial port, DCD2 pin
4	RXD2 (RS232)	UART2 RS232 serial port, RXD2 pin
5	TXD2 (RS232)	UART2 RS232 serial port, TXD2 pin
6	DTR2 (RS232)	UART2 RS232 serial port, DTR2 pin
7	RTS2 (RS232)	UART2 RS232 serial port, RTS2 pin
8	CTS2 (RS232)	UART2 RS232 serial port, CTS2 pin
9	GND	Ground
10	TX+ (RS422)	UART2 RS422 serial port, TX+ pin
11	TX- (RS422)	UART2 RS422 serial port, TX- pin
12	RX+ (RS422)	UART2 RS422 serial port, RX+ pin
13	RX- (RS422)	UART2 RS422 serial port, RX- pin
14	Vout	3.3 VDC Output (max. 100 mA)

Table 1: Pinout environment interface

5.2 RS232 Connector (UART1)

Top view	Pin	Name	Function
	1	DCD1	UART1 serial port, DCD pin
	2	RXD1	UART1 serial port, RXD pin
	3	TXD1	UART1 serial port, TXD pin
	4	DTR1	UART1 serial port, DTR pin
	5	GND	Ground
	6	---	Not connected
	7	RTS1	UART1 serial port, RTS pin
	8	CTS1	UART1 serial port, CTS pin
	9	---	Not connected

Table 2: Pinout RS232 connector (UART1)

Note: All UART1 port signals are on RS232 level. There is no TTL level available on UART1.

5.3 10/100 Mbps Ethernet Interface

Top view	Pin	Name	Function
	1	TX+	10/100 Mbps LAN, TX+ pin
	2	TX-	10/100 Mbps LAN, TX- pin
	3	RX+	10/100 Mbps LAN, RX+ pin
	4	---	Not connected
	5	---	Not connected
	6	RX-	10/100 Mbps LAN, RX- pin
	7	---	Not connected
	8	---	Not connected

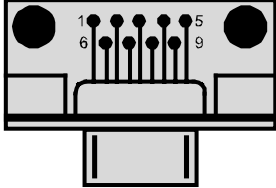
Table 3: Pinout 10/100 Mbps Ethernet interface

CONTACT

SSV Embedded Systems
Heisterbergallee 72
D-30453 Hannover / Germany
Phone: +49 (0)511/40 000-0
Fax: +49 (0)511/40 000-40
E-mail: sales@ist1.de
Internet: www.ssv-embedded.de

DOCUMENT HISTORY

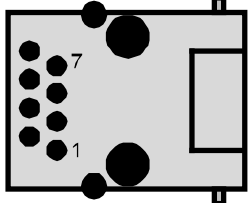
Revision	Date	Remarks	Name
1.0	2005-04-07	first version	WBU
1.1	2005-09-22	errors corrected, chapter 2 modified	WBU
1.2	2005-09-29	chapters 4.1, 4.2 and 4.3 added	WBU
1.3	2006-01-09	errors corrected	WBU

COPYRIGHT

The content of this document can change any time without announcement. There is taken over no guarantee for the accuracy of the statements. The user assumes the entire risk as to the accuracy and the use of this document. Information in this document is provided 'as is' without warranty of any kind. Some names within this document can be trademarks of their respective holders.

© 2006 SSV EMBEDDED SYSTEMS. All rights reserved.